

HYDRAULIC POWER UNITS

TOP MOUNT TANK

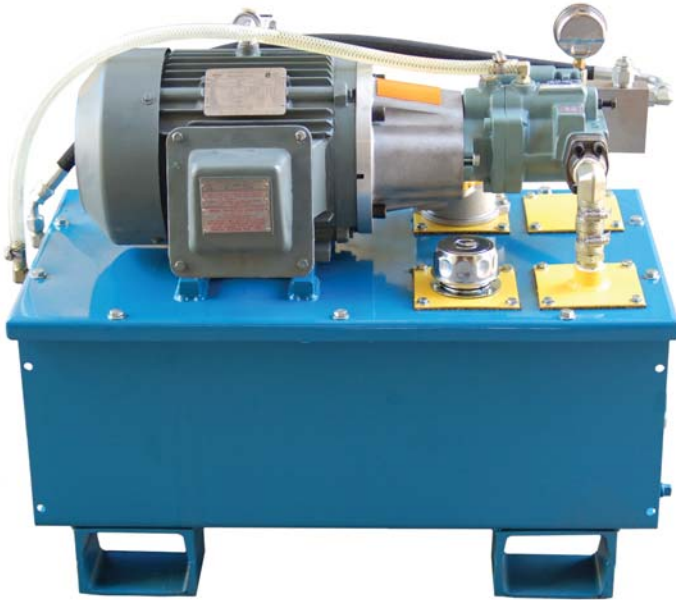

Top Mount Series



TMT20 Top Mount Tank

Features

- Pump and Motor Accessible:** Ability to replace easily.
- Easy Reservoir Draining:** Pump not required for draining.
- Color Code Identification:** Allows for easy identification of items.
- In-Tank Filter System:** Provides easy element replacement without line drainage.
- Convenient Suction Strainer Maintenance:** Clean out access cover allows replacement of suction strainer without draining reservoir.
- Removable Top Plate:** Removable top allows for easy reservoir cleaning. No leaky end bells that make access for cleaning difficult.
- Conserves Space:** While still allowing easy maintenance, the top mount tank design saves floor space.

Dimensional Data

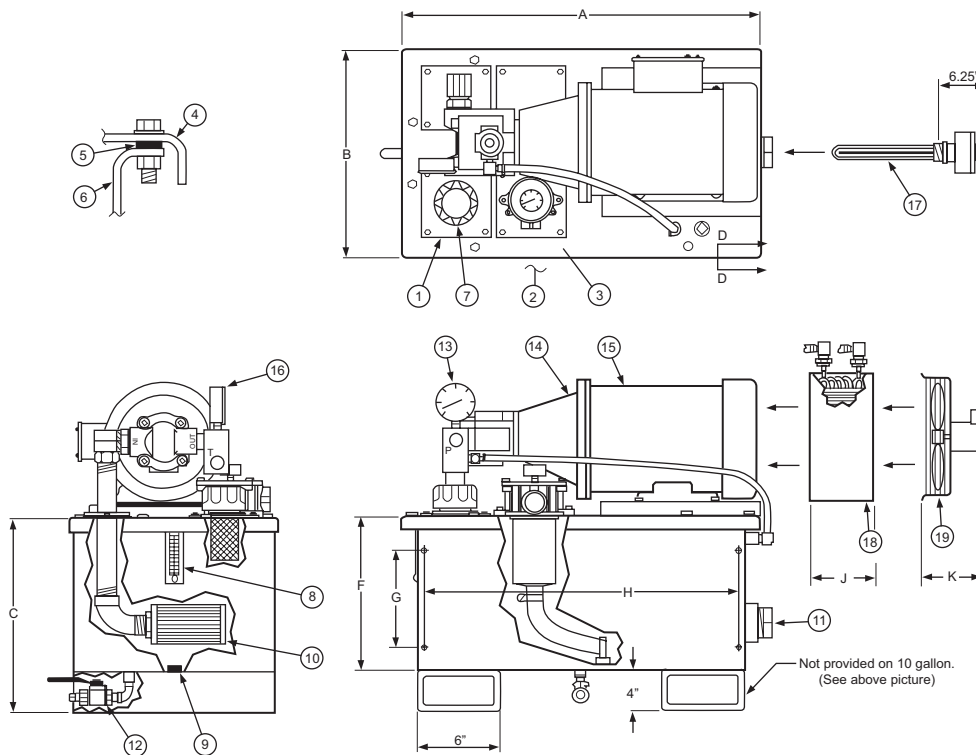

ITEM IDENTIFICATION:

- CLEAN-OUT COVER (YELLOW)
- VALVE MOUNTING AREA
- RETURN FILTER (YELLOW)
- TANK LID
- RUBBERIZED GASKET
- TANK BODY
- FILLER/ BREATHER
- SIGHT & TEMPERATURE GAUGE
- MAGNETS (1 PER 5 GALLONS)
- SUCTION STRAINER WITH BYPASS VALVE
- 2" NPT HEATER COUPLING (OPTIONAL)
- 1/2" NPT DRAIN BALL VALVE WITH PLUG
- PUMP
- PUMP MOTOR ADAPTER (ORANGE)
- ELECTRIC MOTOR
- PRESSURE GAUGE WITH SNUBBER
- HEATER (OPTIONAL)
- HEAT EXCHANGER (OPTIONAL)
- COOLING FAN (OPTIONAL)
- PAINT (OPTIONAL)
 COLOR CODES:
 BLUE- UNIT COLOR PAINT
 ORANGE- DANGER
 YELLOW- MAINTENANCE
 GRAY- ELECTRICAL

Model Number	Reservoir Capacity	Dimensions (Inches)								Std. Return Filter (10 μ)	4" Lip Drip Pan	Maximum Horsepower
		A	B	C	F	G	H	J	K			
TMT10	10 Gallon	26.0	15.0	12.3						ITF200-8FS-10MNPE		5
TMT20	20 Gallon	32.0	17.5	16.0	12.0	8	30.6	4.25	5.9	ITF200-12FS-10MNPE	30.9" x 48"	10
TMT35	35 Gallon	36.5	22.5	17.5	13.5	8	35.3	4.25	6.0	ITF250-12FS-10MNPE	30.9" x 48"	15
TMT70	70 Gallon	46.5	26.3	20.5	16.5	8	45.3	4.25	6.0	ITF425-24FS-10MNPE	38.8" x 52"	50
TMT100	100 Gallon	46.5	26.3	26.0	22.0	8	45.3	9.0	6.0	ITF450-24FS-20-10	38.8" x 52"	100
TMT150	150 Gallon	46.5	26.3	37.0	33.0	8	45.3	9.0	6.0	ITF450-24FS-30-10	38.8" x 52"	100



HYDRAULIC POWER UNITS

TOP MOUNT TANK



Top Mount Series

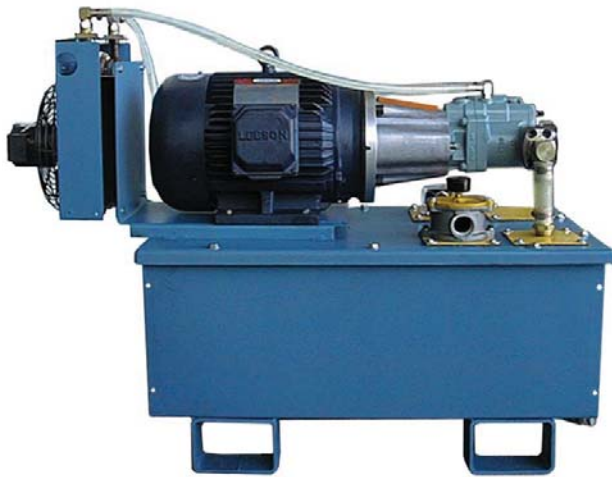

TMT20-10HP-PCP8
Top Mount Tank:
HE90-HF cooler,
DR30 safety relief

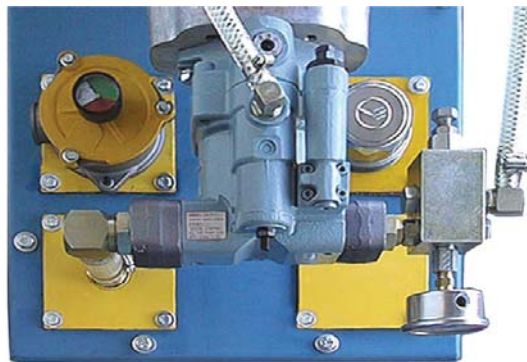

Covers may be relocated:

Fill, suction, return or access plates may be moved as specified by the customer. (units 20+ gallons)

Standard arrangement is same as the dimensional drawing (left).



TMT200- Lubrication System:
We provide the reservoir, pump/ motors, heaters, coolers, modulating valves and Barksdale level, pressure, and temperature controls.

Customer contracts directly with our motor controls house for the electrical package.

