

VANE PUMPS

PCV8 SERIES- 4HV VANE PUMPS



4HV, 4-Bolt



Series PCV8 Vane Pumps

Features

- Variable Volume, Pressure Compensated Design:** Reduces heat, noise and horsepower requirements. Pump maintains constant pressure while matching system flow demands.
- Quiet Operation:** Noise levels as low as 70 dBA.
- Compact and Simple Design:** Dependable operation- compensator not prone to contamination.
- Long Service Life:** Sturdy construction, precise machining ensures durability.
- Volume Adjustment Standard:** Pumps can be reduced as much as 50% of total maximum displacement.

Specifications

PCV8-2K 1750 RPM, 7.9 GPM (at no load), 2000 PSI Max

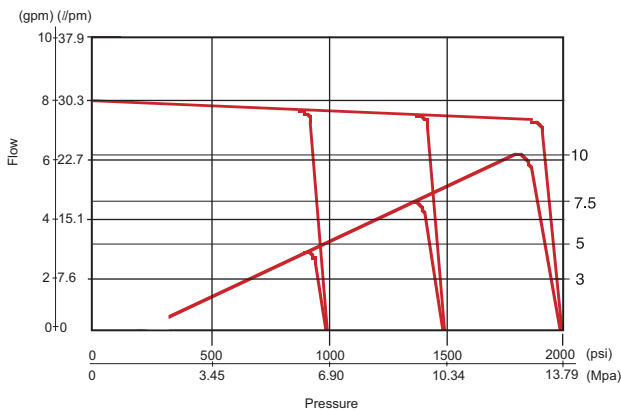

Typical performance curves based on ISO VG46 Oil @120°F, (49°C)

Dimensional Data

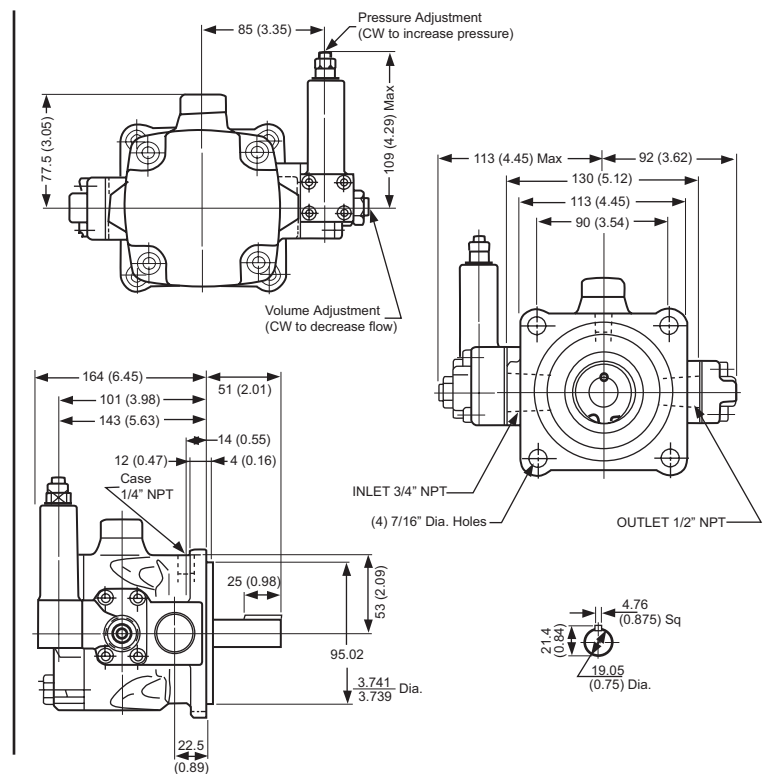

Ordering Information

PCV10 - 1K - 4HV - 1

Note: Available right hand rotation (only)- viewed facing pump shaft

Size (GPM)
8

Code	Press Range
1.5K	500-1500 PSI
2K	1000-2000 PSI

Mounting Style
4-Bolt, 4HV Mount (3.74" dia. pilot & 5.0" bolt circle), 3/4" Dia. Keyed Shaft x1.45" Long w/ 3/16" Key, w/ Flow Adj.

Series 1 Porting
3/4" inlet, 1/2" outlet, 1/4" case all female NPT

