

PCP8/ 10

Specifications

PCP8 1800 rpm, 7.8 gpm (at no load), 3000 psi max

Model	Pressure Range (psi)	Displacement per rev.	Flow @1800 rpm	Weight
PCP8-.5K-2AK-2	143-500	1.01 cu-in 16.5 cc	7.8 gpm (29.7 lpm)	23.0 lbs 10.5 kgs
PCP8-1K-2AK-2	286-1000			
PCP8-2K-2AK-2	500-2000			
PCP8-3K-2AK-2	500-3000			

Performance Data

Typical performance curves based on ISO VG32 Oil @ 120°F, (49°C)

Efficiency Curves

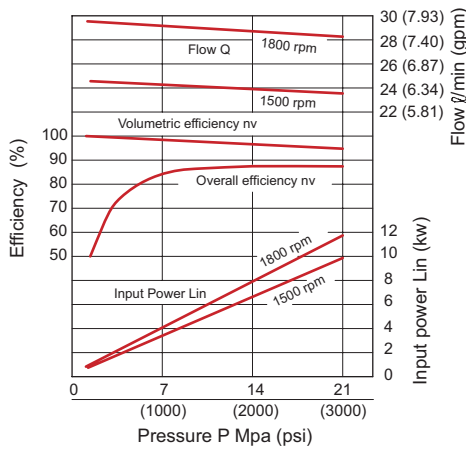

Pressure vs Flow

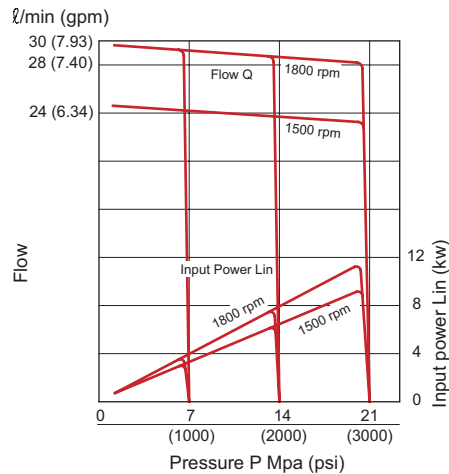

Power Input

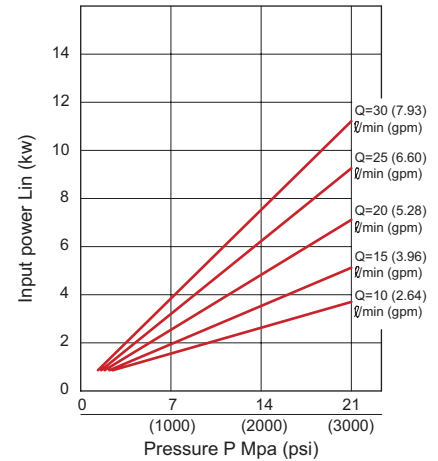

Deadhead Power

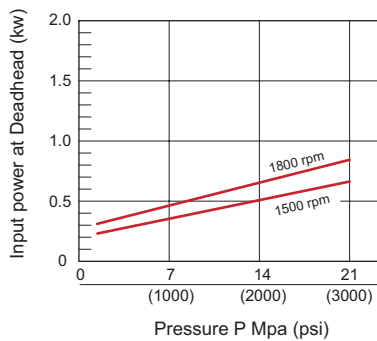

Noise Level

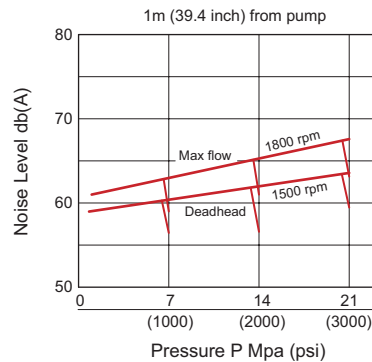

Drain Curve

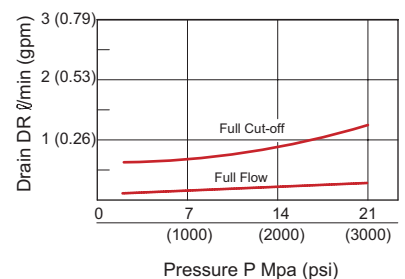

Specifications

PCP10 1800 rpm, 10.5 gpm (at no load), 3000 psi max

Model	Pressure Range (psi)	Displacement per rev.	Flow @1800 rpm	Weight
PCP10-.5K-2AK-2	143-500	1.34 cu-in 22.2 cc	10.5 gpm (39.6 lpm)	23.0 lbs 10.5 kgs
PCP10-1K-2AK-2	286-1000			
PCP10-2K-2AK-2	500-2000			
PCP10-3K-2AK-2	500-3000			

Performance Data

Typical performance curves based on ISO VG32 Oil @ 120°F, (49°C)

Efficiency Curves

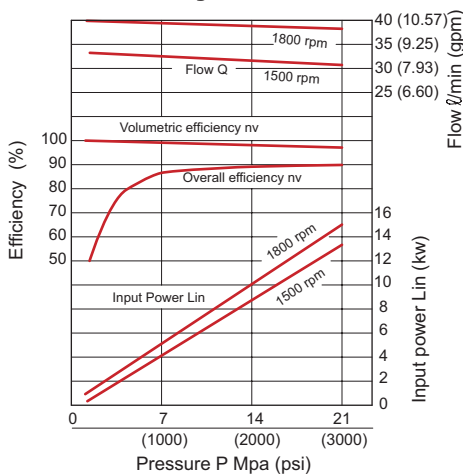

Pressure vs Flow

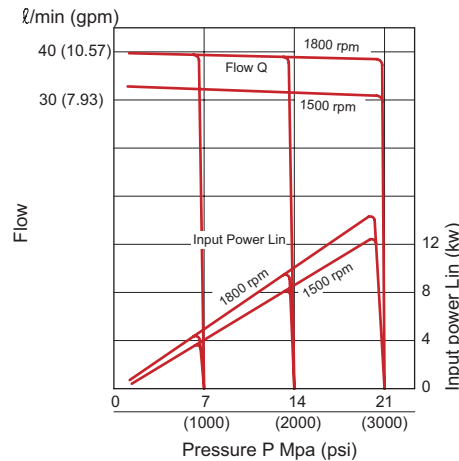

Power Input

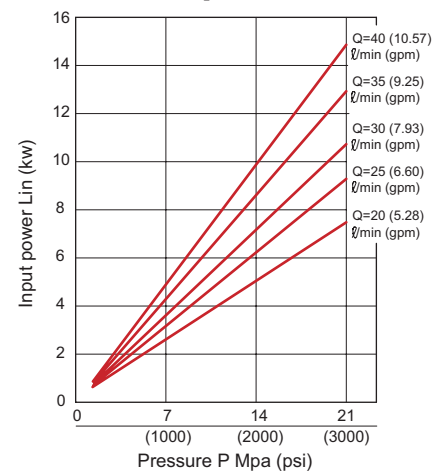

Deadhead Power

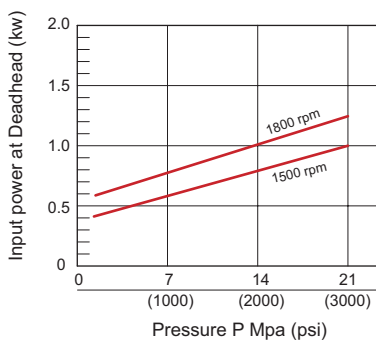

Noise Level

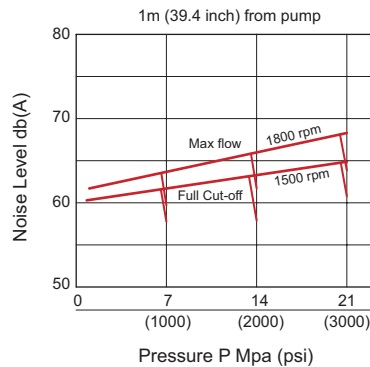

Drain Curve

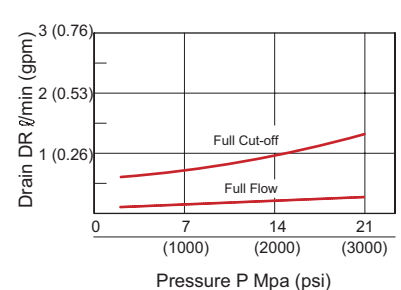

Dimensional Data

PCP8/10-3K-2AK-2

Units: mm (inches)
Weight: 23.0 lbs/ 10.5 kgs

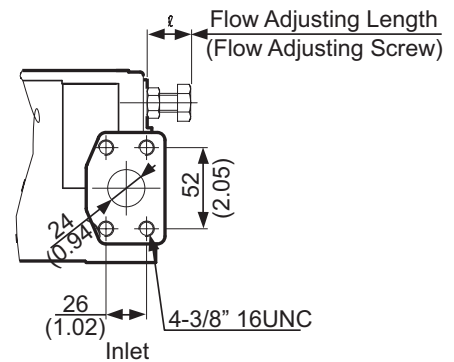
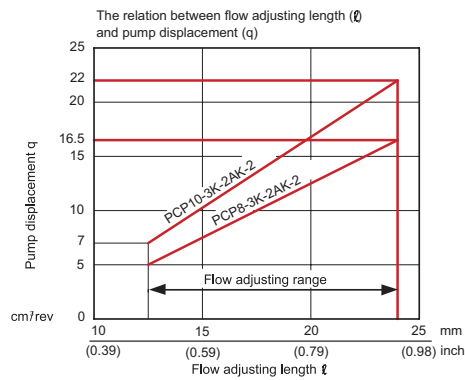
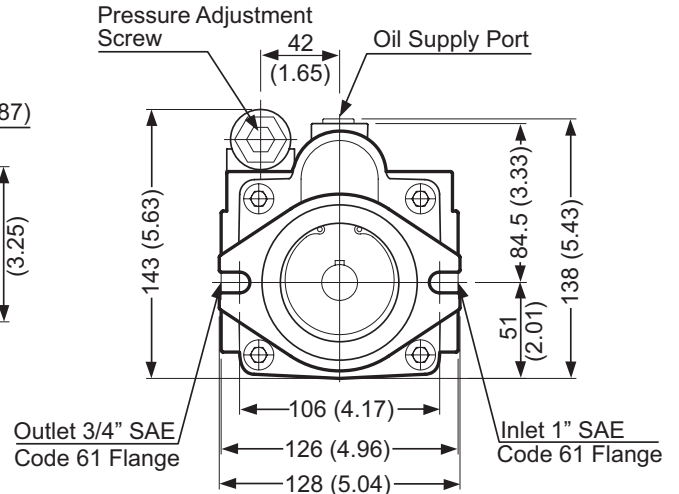
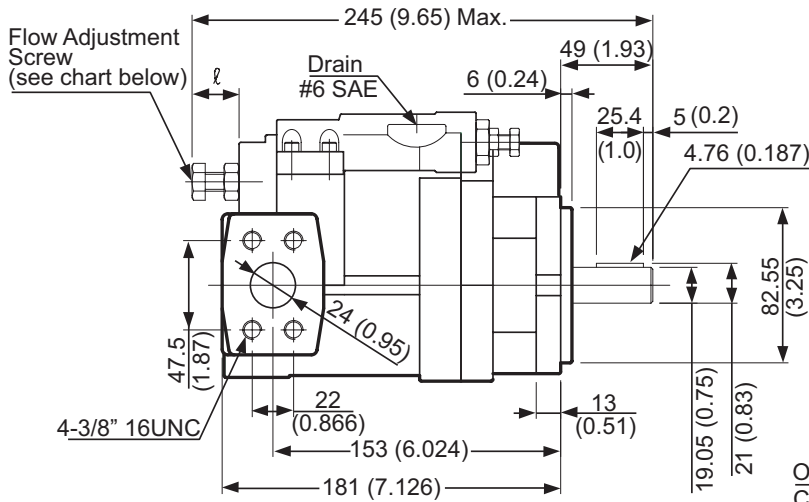

PCP8/10-3K-2AS-2

Units: mm (inches)
Weight: 23.0 lbs/ 10.5 kgs

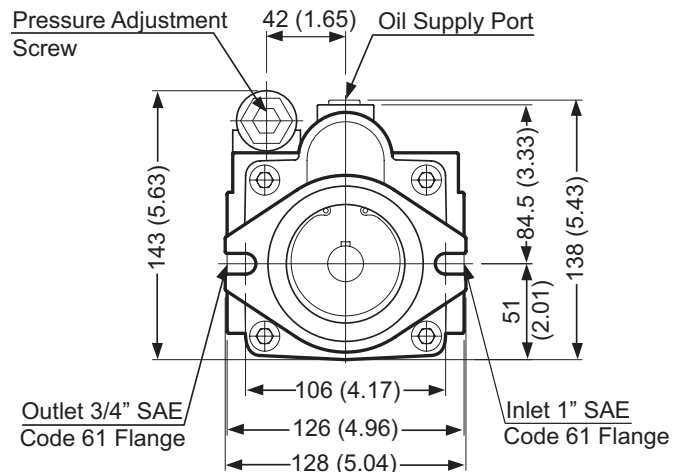
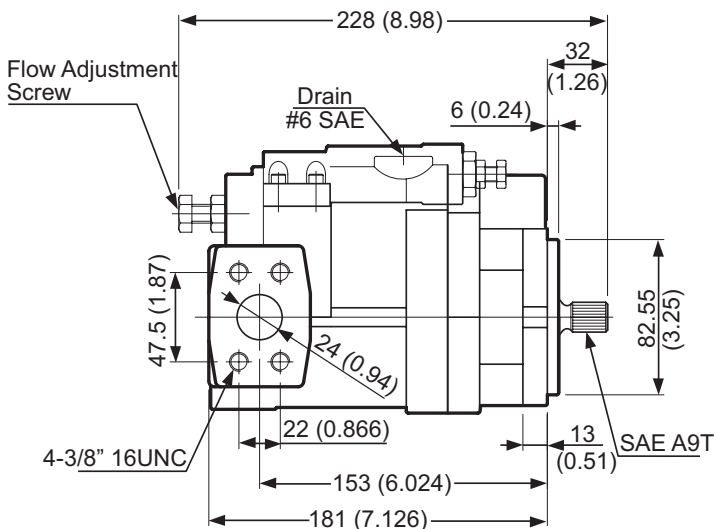

Dimensional Data

PCP8/10-3K-2AK-2AS-2

Units: mm (inches)
Weight:

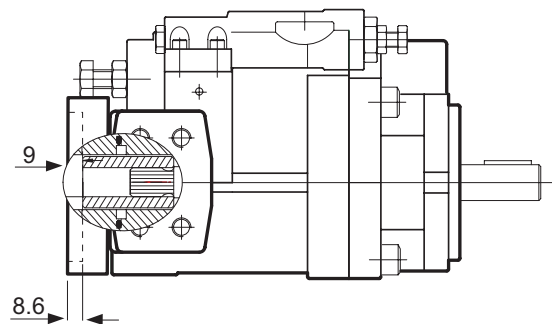
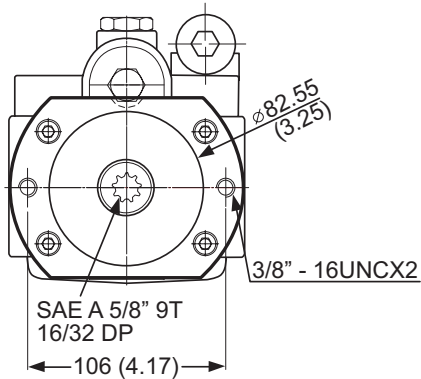
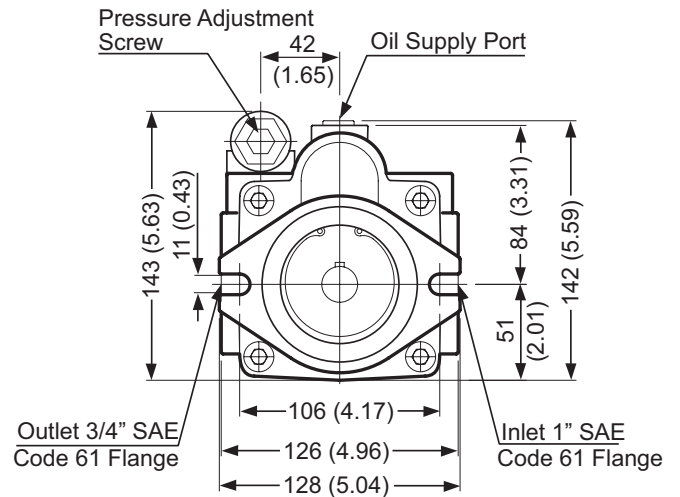
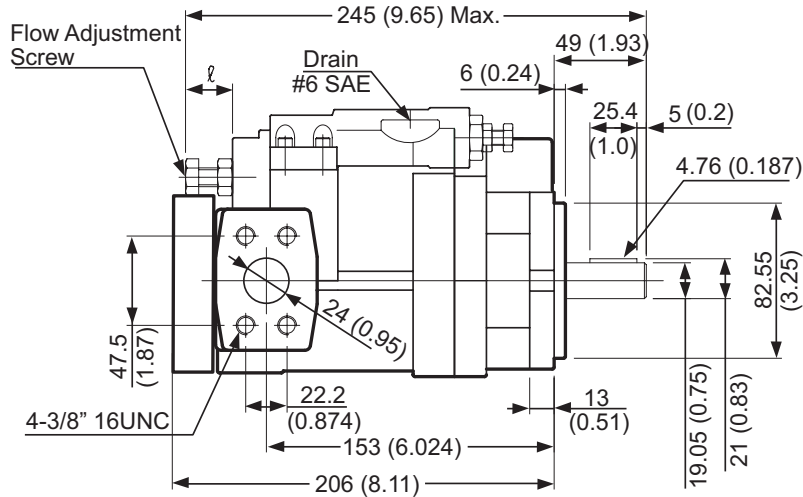

Dimensional Data

PCP8/10-3K-2AK-2-LS

Units: mm (inches)
Weight: 24.1 lbs/ 10.9 kgs

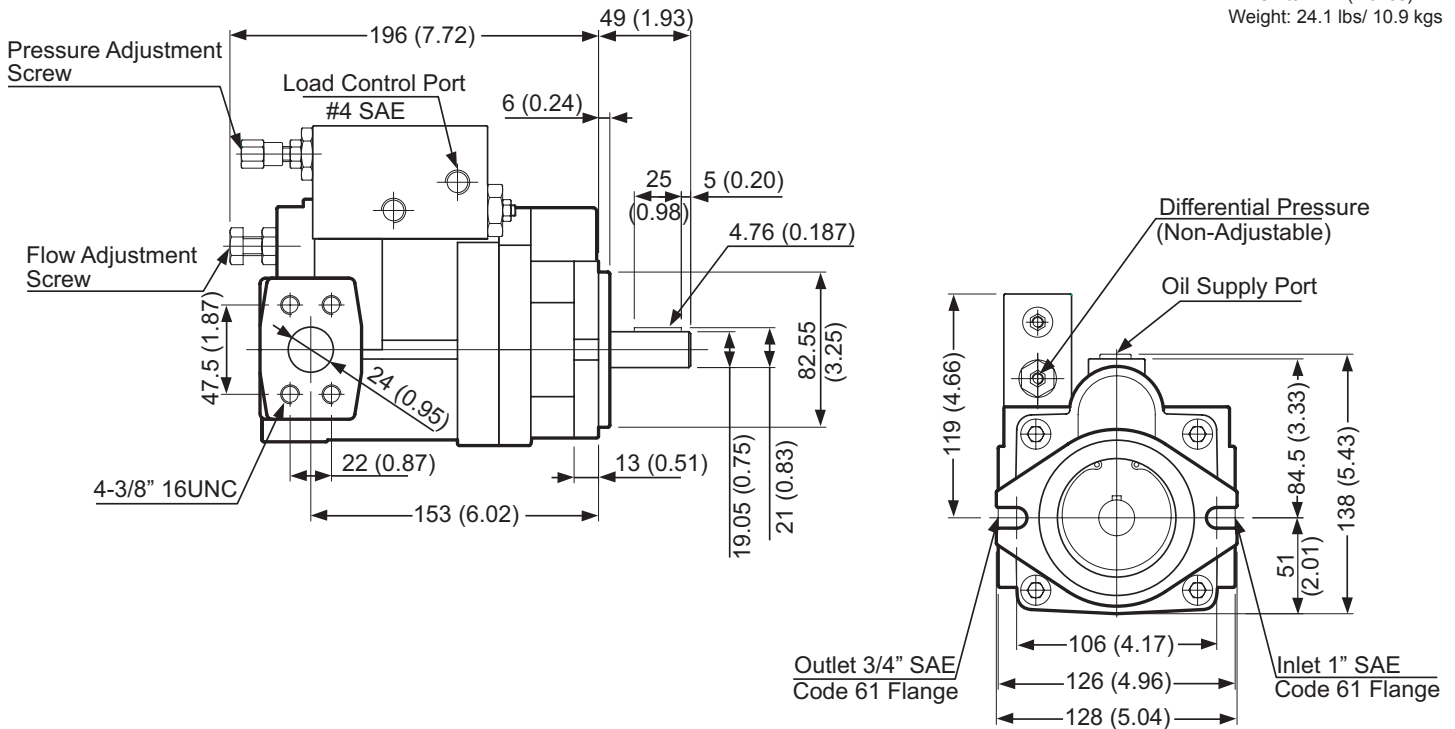

PCP8/10-3K-2AK-2-2PSO

Units: mm (inches)
Weight: 31.1 lbs/ 14.1 kgs

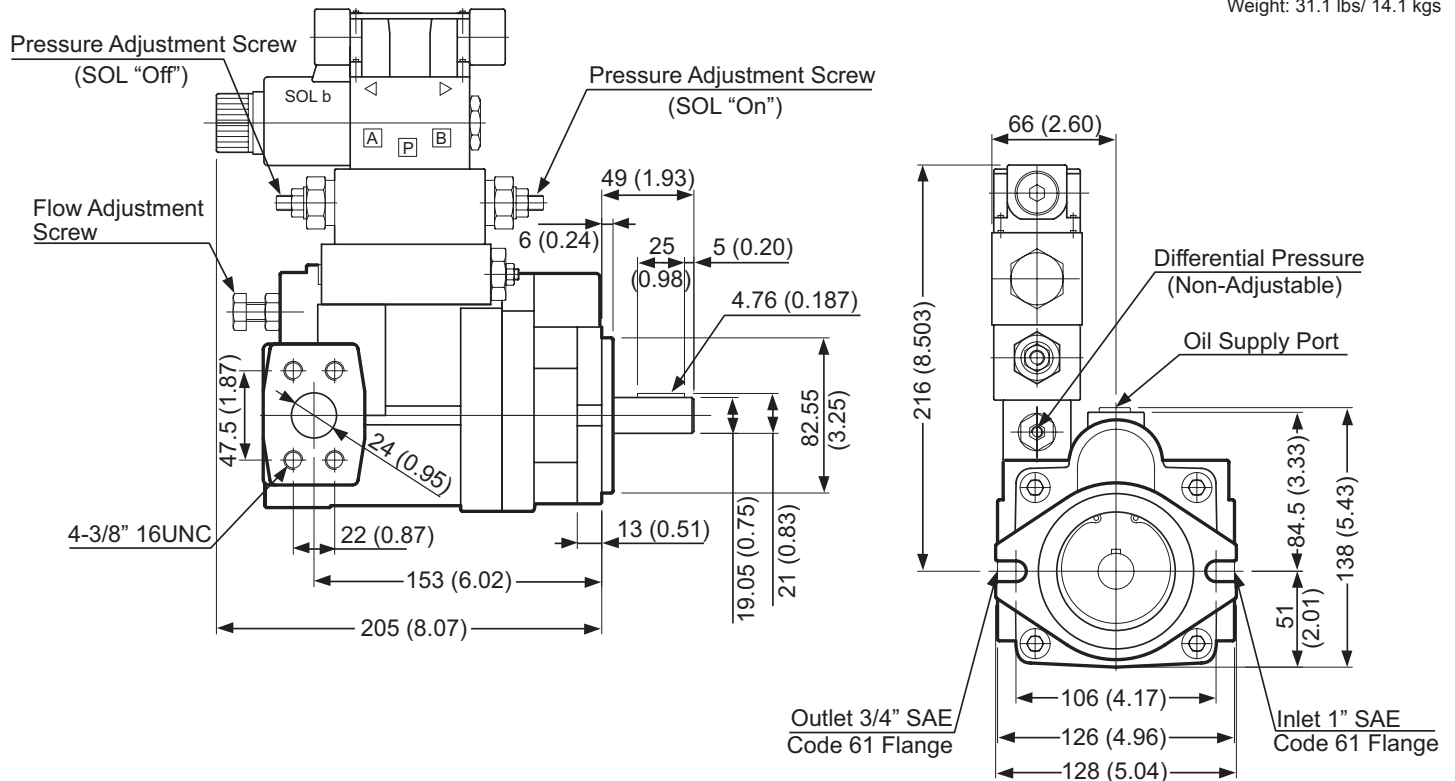

Dimensional Data

PCP8/10-3K-2AK-2-RC

Units: mm (inches)
Weight: 23.0 lbs/ 10.5 kgs

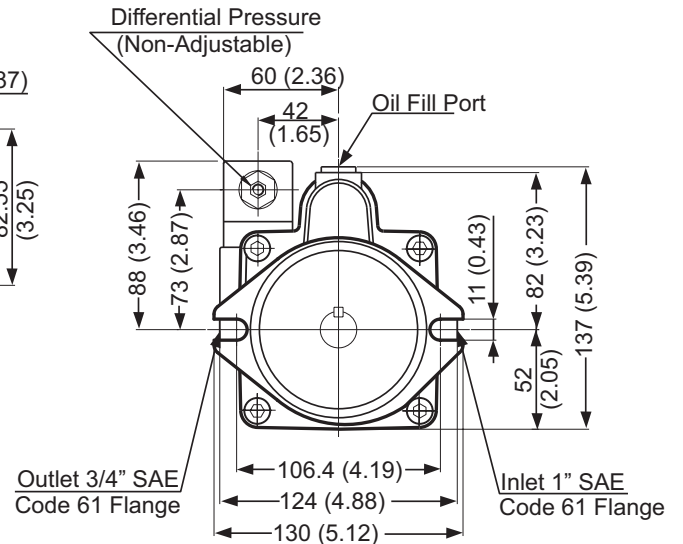
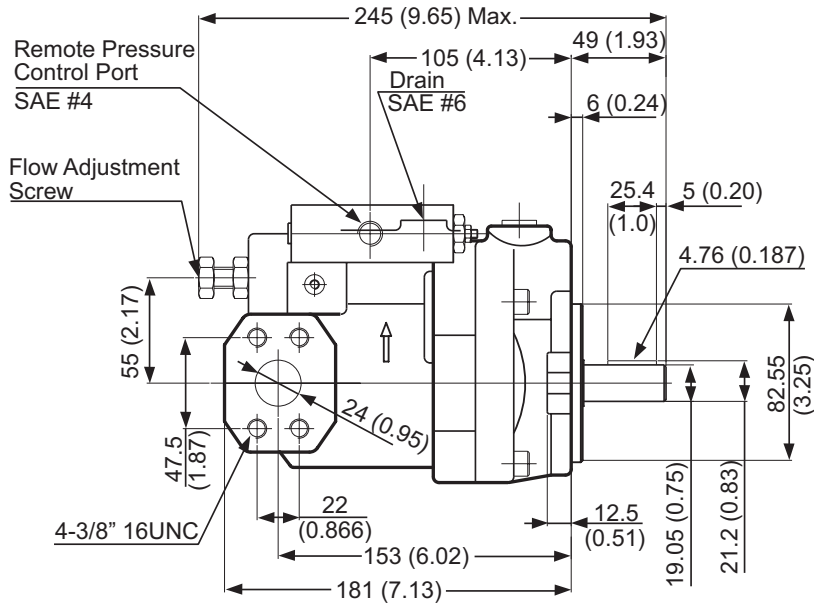

PCP8/10-3K-2AK-2-2P2F

Units: mm (inches)
Weight: 23.0 lbs/ 10.5 kgs

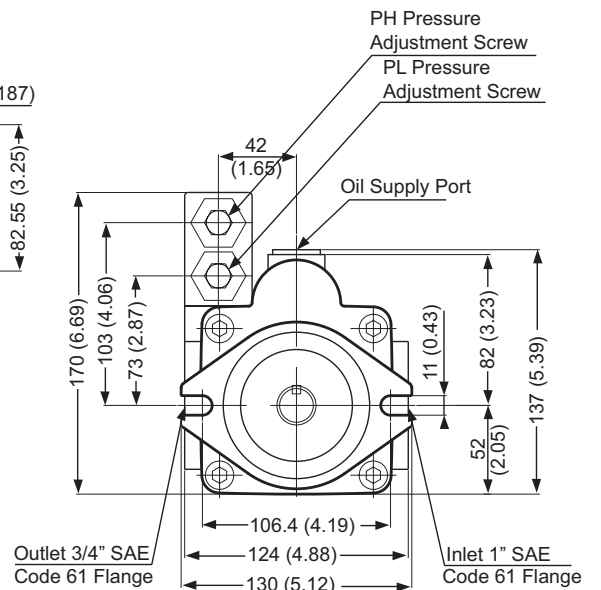
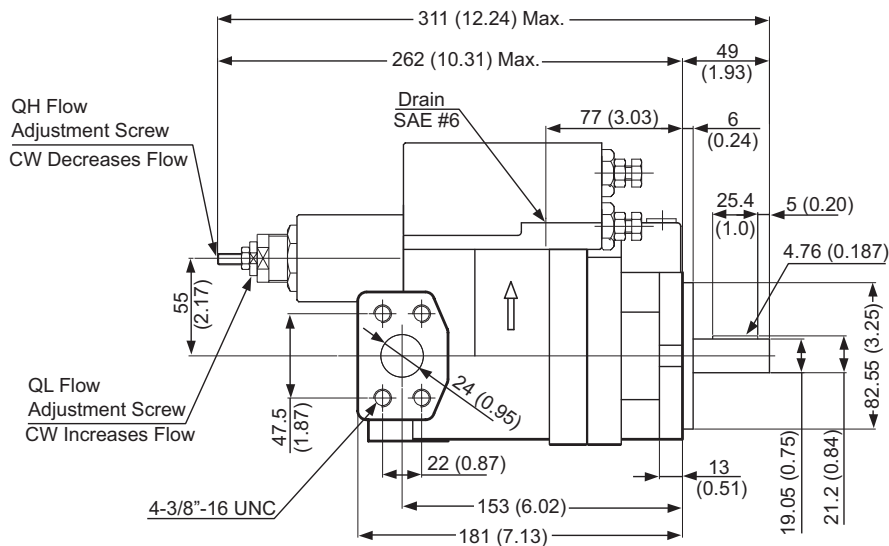

Dimensional Data

PCP8/10-3K-2AK-2-SO

Units: mm (inches)
Weight: 27.8 lbs/ 12.6 kgs

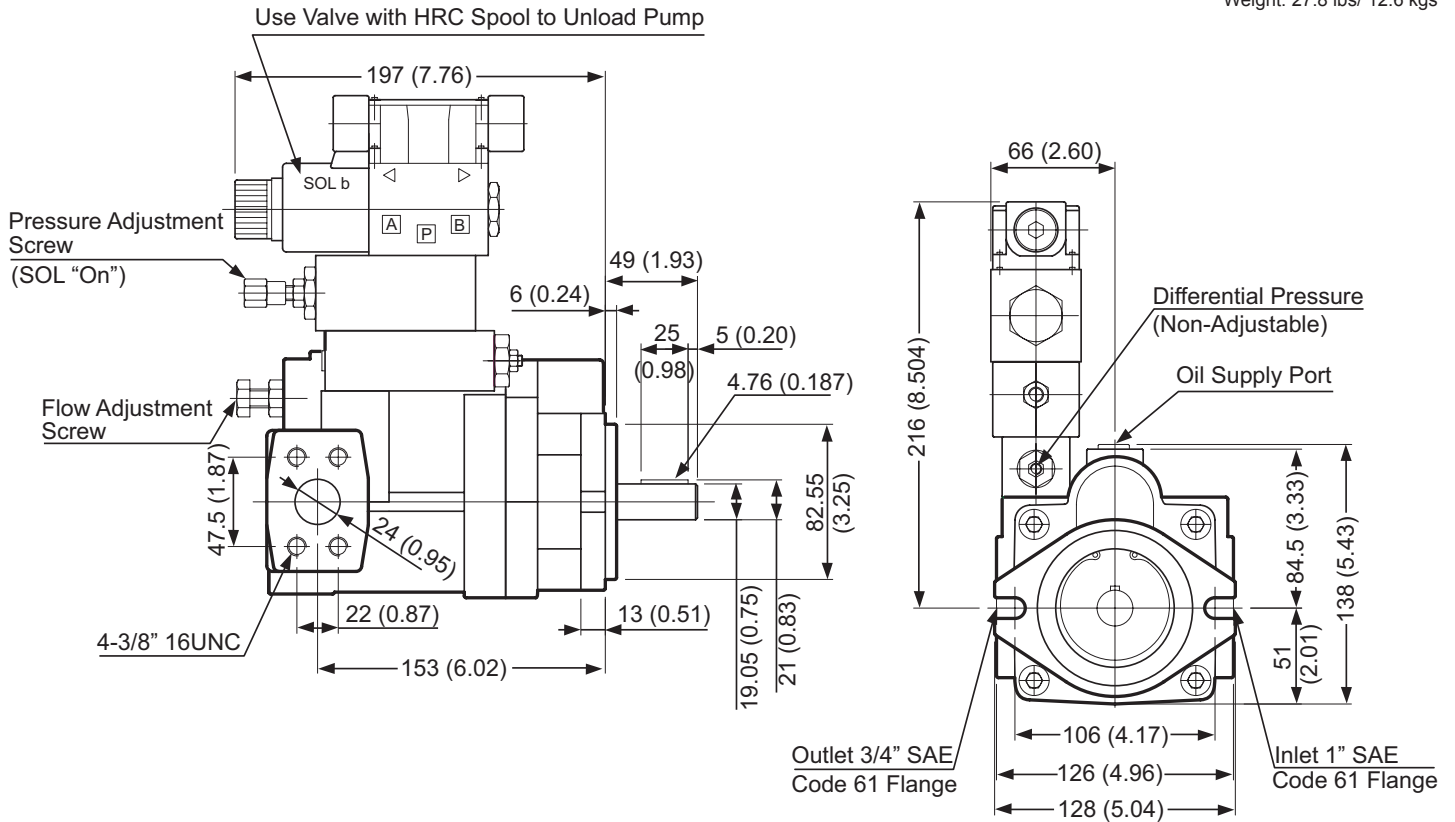

Ordering Information

PCP8 - 3K - 2AK - 2AS - 2 - RC

Note: Available right hand rotation (only)- viewed facing pump shaft

