

SMALL POWER UNITS

HT SERIES- DC HORIZONTAL TANK



HT Series

Ordering Information

HT 2 - 12VDC - G.7 - DVP

Gallons	Volts	Flow	Option
0.8	12	.7 (GPM@1800)	DV Dump Valve
1.3	24		DVP Dump Valve w/ Pendant
2			

Rated @ 2500 PSI Max.
Intermittant Duty



HT Series DC Motor

Standard Configuration

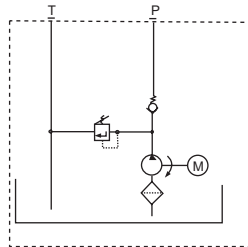

Hyd. Schematic

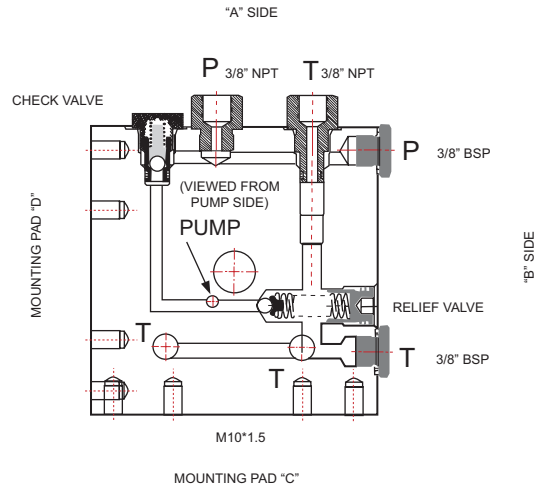

With Lowering Valve- DV

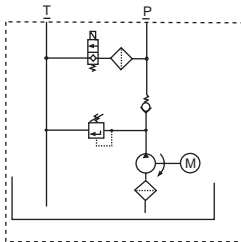

Hyd. Schematic

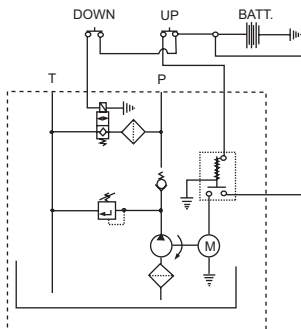

Hyd. Schematic & Electric Schematic

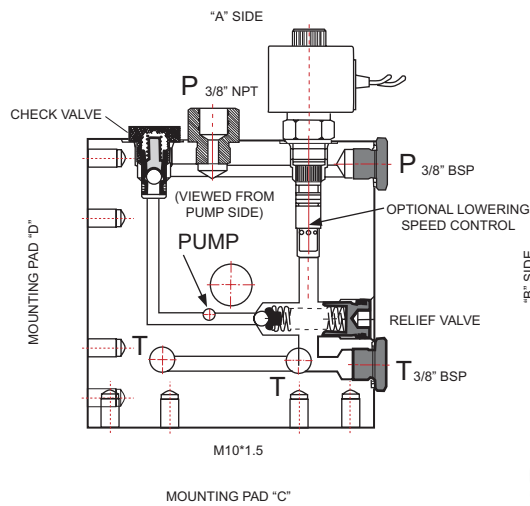

(Red Wire is Common)

Unit supplied with 2 button pendant w/ 4 meter cable.



SMALL POWER UNITS

HT SERIES- DC HORIZONTAL TANK



HT Series

Dimensional Data

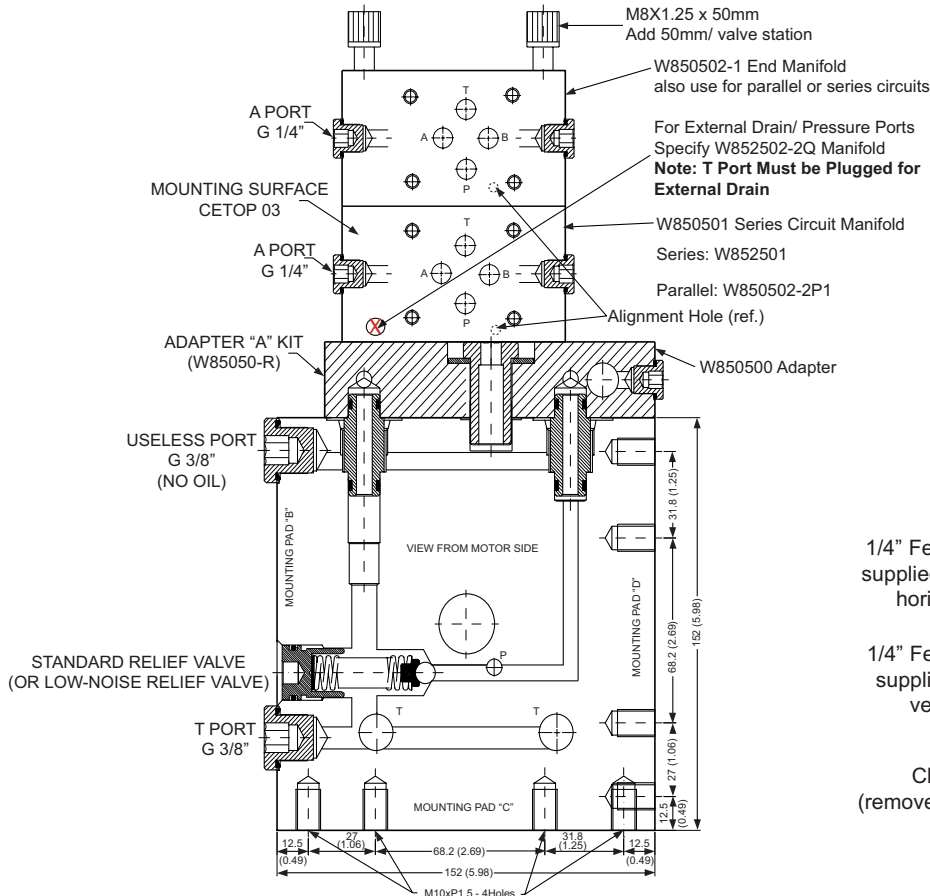
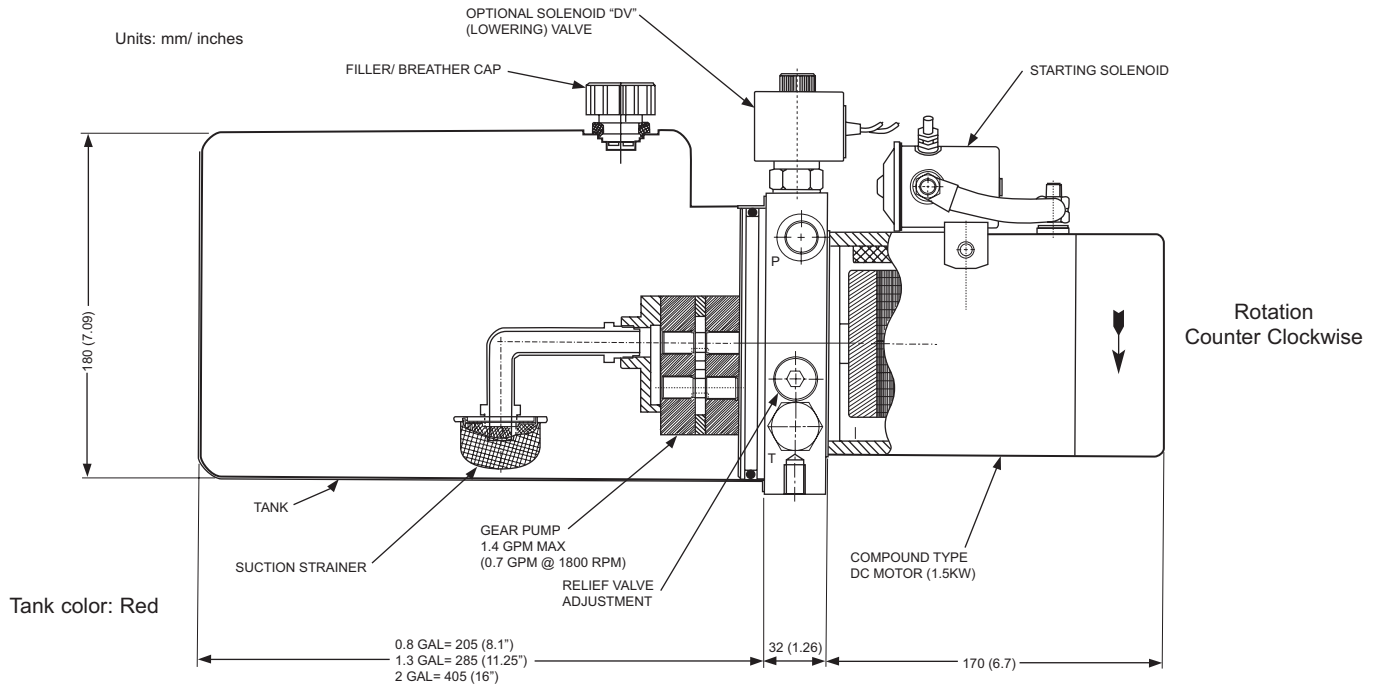

Optional Manifolds



TOP

1/4" Female Adapters supplied on bottom for horizontal units

1/4" Female Adapters supplied on side for vertical units

Check Valve (removed from "A" side)

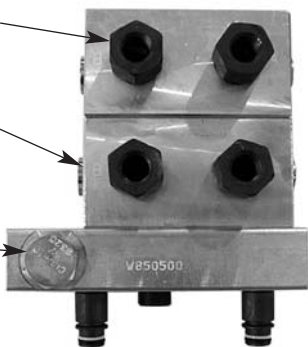

BOTTOM



SMALL POWER UNITS

HT SERIES- DC HORIZONTAL TANK



HT Series

Parts Breakdown

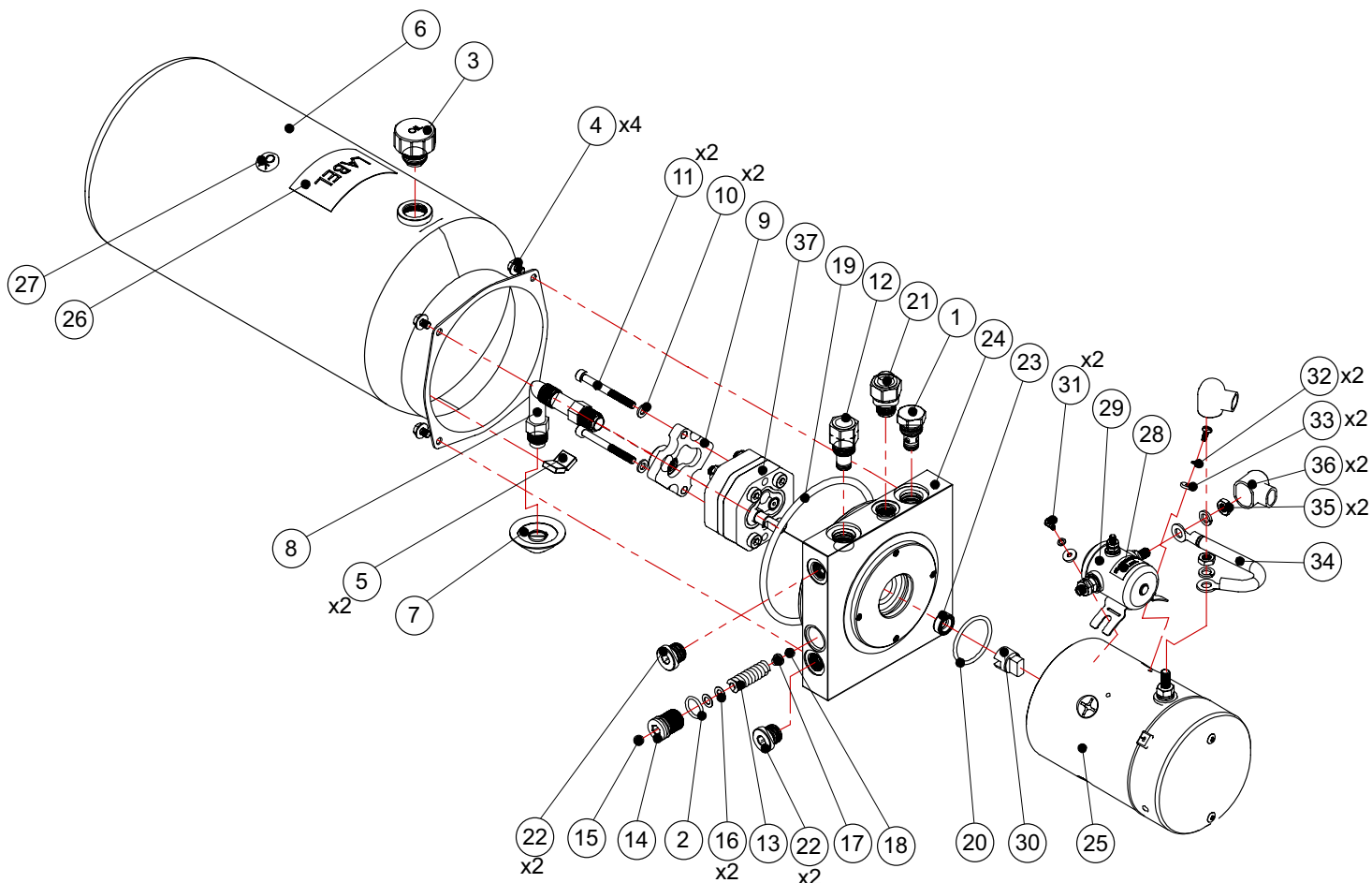

Parts Breakdown

1) Check Valve	11) Socket Head Cap Screw	21) Adapter Joint	31) M4 Screw
2) O-Ring	12) Plug	22) Plug	32) Spring Washer
3) Filler/ Breather	13) Spring	23) Shaft Seal	33) Washer
4) M6 Screw	14) Adjustable Knob	24) Manifold	34) Cable
5) Magnet	15) Plastic Ball	25) DC Motor	35) Nut
6) Tank	16) Washer	26) Label	36) Cable Cover
7) Suction Filter	17) Spring Seating	27) Label	37) Gear Pump
8) Suction Tube	18) Steel Ball	28) Label	
9) Suction Cover	19) O-Ring	29) Solenoid Starter Switch	
10) Spring Washer	20) O-Ring	30) Oldham Coupling	

