

AUTOMATIC RECIPROCATING VALVES

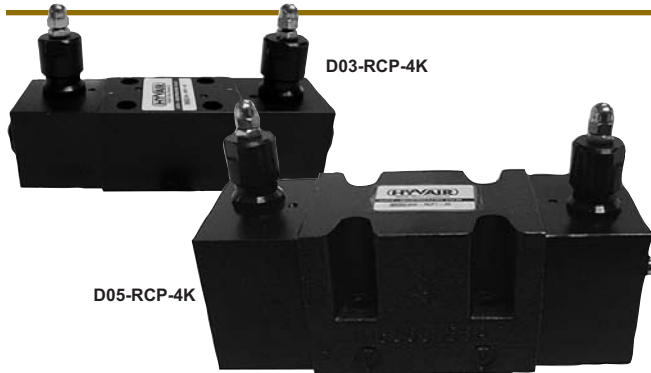

PRESSURE SHIFTING

D03 & D05



D03 & D05 Automatic Reciprocating Valves

This valve type is characterized by fully hydraulic operation, as it takes advantage of the system pressure rise to cause an automatic and continuous inversion of the utilization. The changeover takes place when the system pressure exceeds the inversion valves calibration pressure, and therefore also in not predetermined positions. At cylinder stroke end, the overall maximum pressure valve should be adjusted on a value 30% higher than the system operating pressure. The inverter valves pressure calibration values should be 15% lower than that of the overall maximum pressure valve, and 15% higher than the maximum operating pressure. Note: to operate the push button emergency, a minimum pressure of 3 bar on the actuator is needed.

NFPA Size	Model	Pressure Shifting Range	Min. Flow gpm/ (lpm)	Max. Flow gpm/ (lpm)	Weight lb/ (kg)	Min. Pressure	Max. Pressure
D03	D03-RCP-2K	290-2000 psi	0.5 (2.0)	6.6 (25)	5.0 (2.3)	290 psi (20 bar)	4000 psi (275bar)
	D03-RCP-4K	725- 4000 psi					
D05	D05-RCP-2K	290-2000 psi	1.6 (6.0)	18.5 (70)	11.9 (5.4)		
	D05-RCP-4K	725- 4000 psi					

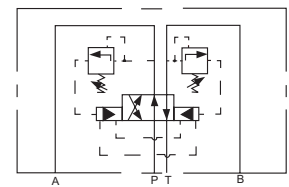

D03 Pressure Drops

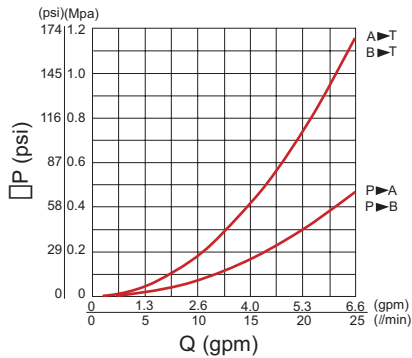

D05 Pressure Drops

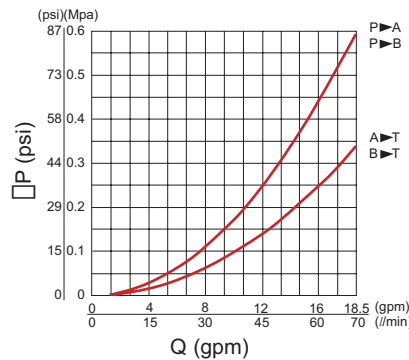

Operating Notes:

- Fluid viscosity: 80-300 SUS (17-65cSt)
- Fluid temperature: 40-160F° (5°-70°C)
- Max. contamination level: 25 micron (class 8 NAS 1638)

Dimensional Data

D03-RCP

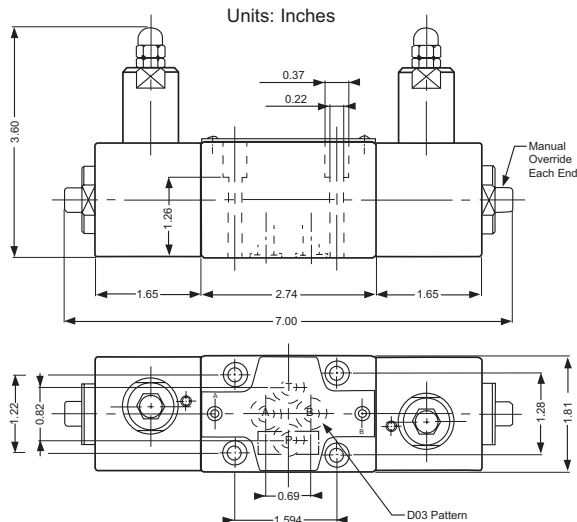

Mounting Torque: 40 in-lbs
(4) 10-24 SHCS x 1.75" long supplied

D05-RCP

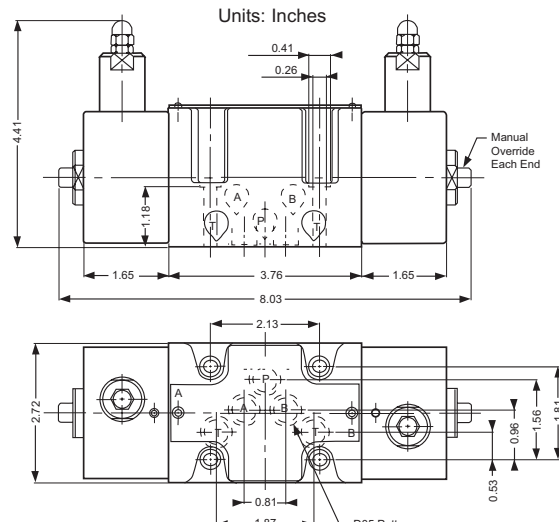

Mounting Torque: 80 in-lbs
(4) 1/4-20 SHCS x 1.50" long supplied

